

# HYDER AGR-PUD SOUTH PLAT ONE

64

BEING A REPLAT OF ALL OF TRACTS 27 THROUGH 31, TRACTS 34 THROUGH 36, TRACTS 61 THROUGH 63 AND A PORTION OF TRACTS 1 THROUGH 9, TRACTS 24 THROUGH 26, TRACTS 37 THROUGH 40, A PORTION OF TRACTS 32, 33, 60, 64 AND A PORTION OF THE ROAD, DYKE AND DITCH RESERVATIONS, 30.00 FEET IN WIDTH, BLOCK 70, PALM BEACH FARMS CO. PLAT NO. 3, ACCORDING TO THE PLAT THEREOF, AS RECORDED IN PLAT BOOK 2, PAGES 45 THROUGH 54, PUBLIC RECORDS, PALM BEACH COUNTY, FLORIDA, LYING IN SECTIONS 31 AND 32, TOWNSHIP 46 SOUTH, RANGE 42 EAST.

SHEET 2 OF 15

MATCH LINE  
(SEE SHEET 10)

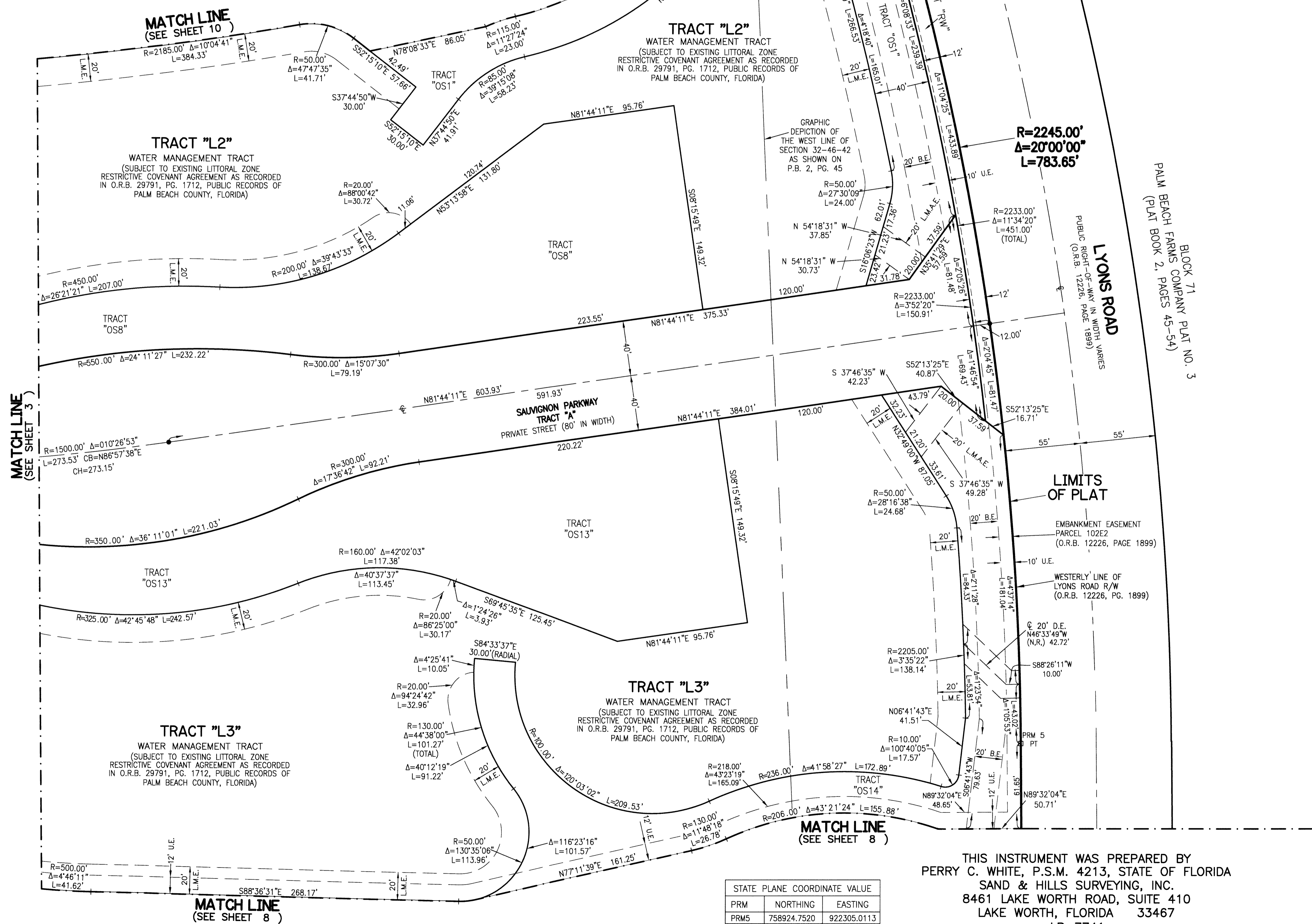
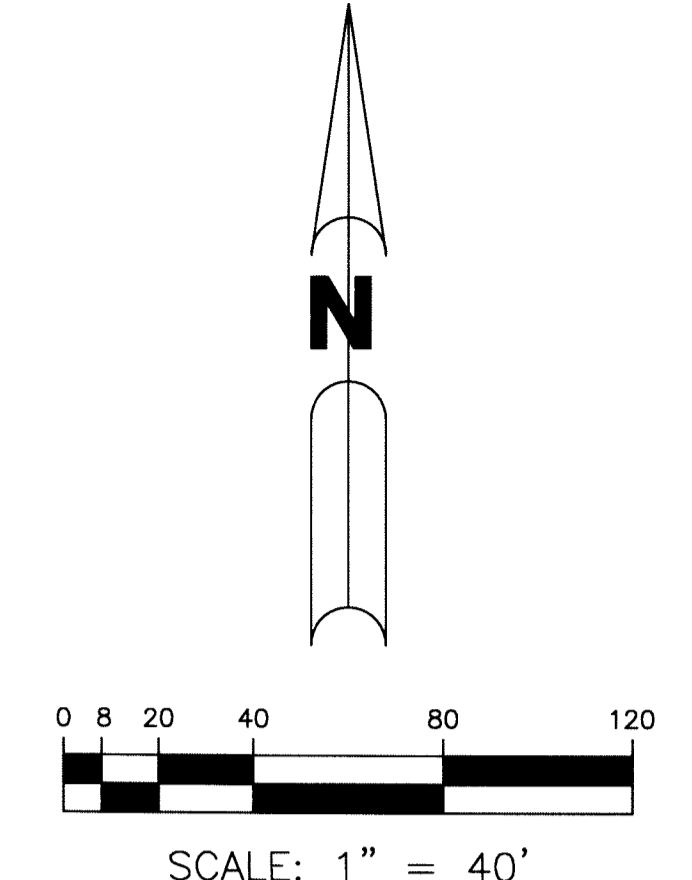

**LEGEND:**

- - SET PERMANENT REFERENCE MONUMENT  
4"x4" CONCRETE MONUMENT WITH  
1.5" DISK STAMPED L.B. #7741
- - FOUND PERMANENT REFERENCE MONUMENT  
4"x4" CONCRETE MONUMENT WITH  
1.5" DISK STAMPED L.B. #7741
- - SET PERMANENT CONTROL POINT  
NAIL WITH 1.25" DISK STAMPED L.B. #7741
- - FOUND PERMANENT CONTROL POINT  
NAIL WITH 1.25" DISK STAMPED L.B. #7741
- AGR - AGRICULTURAL
- Δ - DELTA ANGLE
- B.E. - BUFFER EASEMENT
- BLK - BLOCK
- CB - CHORD BEARING
- CH - CHORD DISTANCE
- ⊙ - CENTERLINE
- D.B. - DEED BOOK
- D.E. - PRIVATE DRAINAGE EASEMENT
- F.P.L. - FLORIDA POWER & LIGHT
- L - ARC LENGTH
- L.A.E. - LIMITED ACCESS EASEMENT
- L.M.A.E. - LAKE MAINTENANCE ACCESS EASEMENT
- L.M.E. - LAKE MAINTENANCE EASEMENT
- L.W.D. - LAKE WORTH DRAINAGE DISTRICT
- N.R. - NOT RADIAL
- N.T.S. - NOT TO SCALE
- O.R.B. - OFFICIAL RECORD BOOK
- O.E. - MAINTENANCE & ROOF OVERHANG EASEMENT
- P.B.C.U.E. - PALM BEACH COUNTY UTILITY EASEMENT
- P.B. - PLAT BOOK
- P.C. - POINT OF CURVATURE
- P.C.P. - PERMANENT CONTROL POINT
- P.D.E. - PUBLIC DRAINAGE EASEMENT
- PG. - PAGE
- PGS. - PAGES
- P.O.B. - POINT OF BEGINNING
- P.C.C. - POINT OF COMPOUND CURVATURE
- P.O.C. - POINT OF COMMENCEMENT
- PI - POINT OF INTERSECTION
- PRC - POINT OF REVERSE CURVATURE
- PRM - PERMANENT REFERENCE MONUMENT
- P.S.M. - PROFESSIONAL SURVEYOR AND MAPPER
- PT - POINT OF TANGENCY
- P.U.D. - PLANNED UNIT DEVELOPMENT
- R - RADIUS
- RAD - RADIAL
- R/W - RIGHT-OF-WAY
- R.D. & D. - ROAD, DYKE AND DITCH RESERVATION
- S.T. - SURVEY TIE
- TYP. - TYPICAL
- U.E. - UTILITY EASEMENT

**NOTE:**  
 COORDINATES SHOWN ARE GRID COORDINATES DATUM = NAD 83 (1990 ADJUSTMENT)  
 ZONE = FLORIDA EAST ZONE  
 LINEAR UNIT = U.S. SURVEY FEET  
 COORDINATE SYSTEM = 1983 STATE PLANE TRANSVERSE MERCATOR PROJECTION  
 ALL DISTANCES ARE GROUND  
 SCALE FACTOR = 1.00002237  
 PLAT BEARING = GRID BEARING  
 GROUND DISTANCE X SCALE FACTOR = GRID DISTANCE

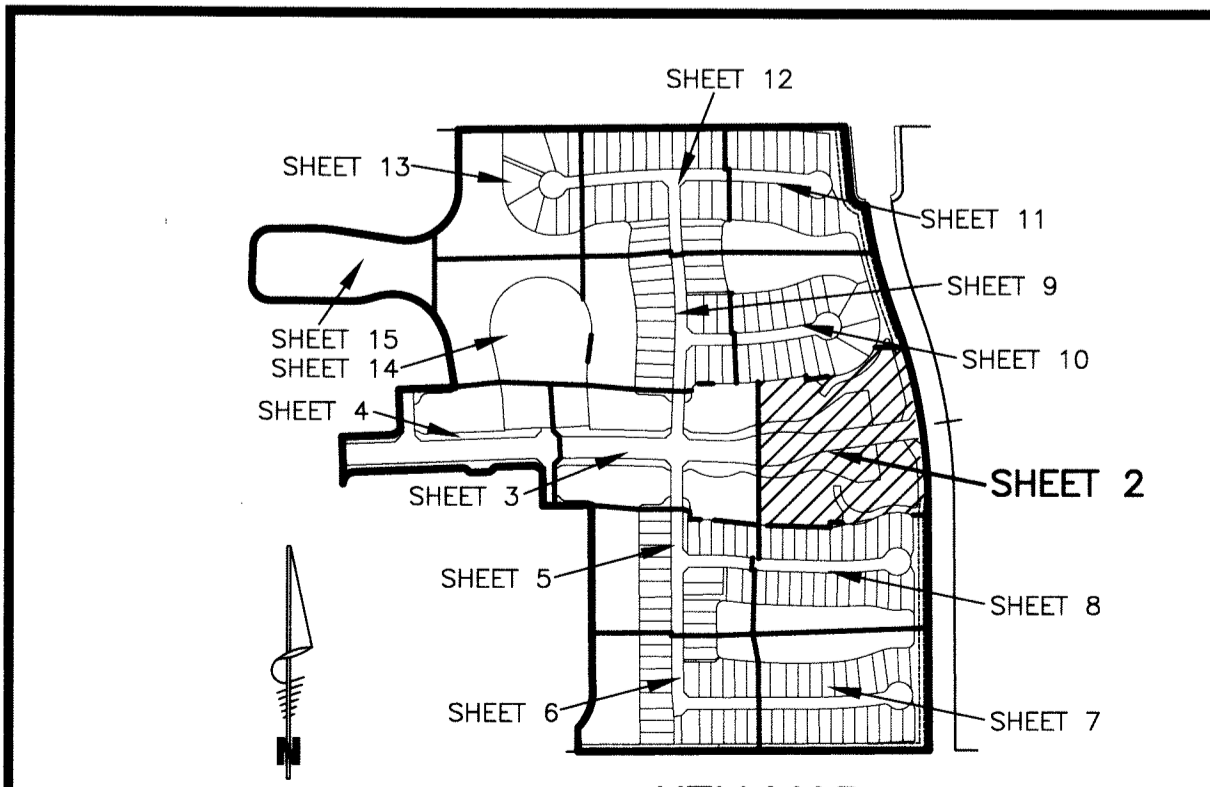

STATE PLANE COORDINATE VALUE		
PRM	NORTHING	EASTING
PRM5	758924.7520	922305.0113

THIS INSTRUMENT WAS PREPARED BY  
 PERRY C. WHITE, P.S.M. 4213, STATE OF FLORIDA  
 SAND & HILLS SURVEYING, INC.  
 8461 LAKE WORTH ROAD, SUITE 410  
 LAKE WORTH, FLORIDA 33467  
 LB-7741